

# BR480

LED Display Control Board



**Specifications**

## Change History

Document Version	Release Date	Description
V1.0.4	2026-04-17	Updated the maximum load capacity.
V1.0.3	2025-10-28	<ul style="list-style-type: none"><li>• Updated output voltage information.</li><li>• Updated the dimensions diagram.</li></ul>
V1.0.2	2025-05-13	<ul style="list-style-type: none"><li>• Updated the load capacity information.</li><li>• Updated the description for uploading coefficients.</li></ul>
V1.0.1	2025-03-03	Added the appearance diagram and net weight information.
V1.0.0	2024-12-31	First release.

## Introduction

The BR480 is an LED display control board developed by NovaStar Tech Co., Ltd. (hereinafter referred to as NovaStar). It integrated a power module converts 90 Vac to 264 Vac into direct current, which directly powers the screen modules. Furthermore, the product offers functions such as undervoltage, overvoltage, overcurrent, overpower, and short-circuit protections, ensuring safety, high efficiency, and good reliability.

For PWM driver ICs, the maximum load capacity per card is:

- 512×384@60Hz (For 8bit video sources)
- 512×256@60Hz (For 10bit and 12bit video sources)

### Note

For PWM driver ICs, the maximum load capacity per card when used with COEX controllers is:

- 512×384@60Hz (For 8 bit and 10 bit video sources)
- 512×256@60Hz (For 12 bit video sources)

## Features

- Power Module and Receiving Card in One Package

The product supports input voltage of 90 Vac to 264 Vac and converts it to direct current to directly power the modules. Furthermore, it offers functions such as undervoltage, overvoltage, overcurrent, overpower, and short circuit protection.

- Thermal Compensation 2.0

Work with NovaStar's high-precision calibration system to precisely collect the thermal distribution data of LED cabinets and generate unique thermal compensation data for each pixel of the cabinets, effectively eliminating the cabinet or module level # shaped bars caused by uneven thermal distribution.

- Color Management

Support standard (Rec.709 / DCI-P3 / Rec.2020) and custom color gamuts, enabling more precise colors on the screen.

- 18bit+

Improve the LED display grayscale by 4 times to avoid grayscale loss due to low brightness and allow for a smoother image.

- HDR

- Support HDR10 and comply with the SMPTE ST 2084 and SMPTE ST 2086 standards.
- Support HLG.

- Pixel Level Brightness and Chroma Calibration

Work with NovaStar's calibration system to calibrate the brightness and chroma of each pixel, effectively eliminating differences and enabling high consistency for both brightness and chroma.

- Quick Adjustment of Dark or Bright Lines

The different brightness of seams caused by splicing of modules or cabinets can be corrected to improve the visual experience. The correction is easy and takes effect immediately.

- Multi-batch Adjustment

Adjust the brightness of cabinets or modules to minimize display discrepancies caused by variations in production batches.

- Low Latency

The latency of video source on the receiving card end can be reduced to 1 frame (only when using modules with driver IC with built-in RAM).

- 3D

Work with the controller that supports 3D function to enable 3D output.

- Individual Gamma Adjustment for RGB

Working with NovaLCT and the controller that supports this function, the receiving card supports individual adjustment to red gamma, green gamma and blue gamma, which can effectively control image non-uniformity at low grayscale conditions and white balance offset, allowing for a more realistic image.

- 90° Image Rotation

The display image can be rotated in multiples of 90° (0°/90°/180°/270°).

- Free Image Rotation

Support image rotation at any angle when using the dedicated MCTRL R5 controller and SmartLCT software.

- Uploading Calibration Coefficients

Upload calibration coefficients to the receiving card quickly or in a stable manner, with acceleration support if needed.

- Module Flash Management

For modules with flash memory, the information stored can be managed, allowing for the storage and readback of calibration coefficients and module IDs.

- Mapping 1.1

The cabinet displays the Ethernet port, receiving card, and controller numbers in different colors, clearly showing the physical locations and connection topology of receiving cards.

- Settings of a Stored Image in the Receiving Card

The image displayed during startup, or displayed when the Ethernet cable is disconnected or there is no video signal can be customized.

- Temperature and Voltage Monitoring

Real-time monitoring of the temperature and voltage of the receiving card, without the need for other external devices.

- Bit Error Detection

Real-time monitoring of the communication of the Ethernet port on the receiving card which helps users troubleshoot network communication problems.

- Firmware Program Readback

The receiving card firmware program can be read back and saved to the local computer.

- Configuration Parameter Readback

The receiving card configuration parameters can be read back and saved to the local computer.

- Loop Backup  
The receiving card and controller form a loop via the primary and backup line connections. When a fault occurs at a location of the lines, the screen can still display the image normally.
- Dual Backup of Configuration Parameters  
The receiving card configuration parameters are stored in the application area and factory area of the receiving card at the same time. Users usually use the configuration parameters in the application area. If necessary, users can restore the configuration parameters in the factory area to the application area.
- Dual Program Backup  
Two copies of firmware program are stored in the receiving card at the factory to avoid the problem that the receiving card may get stuck abnormally during program update.

## Appearance

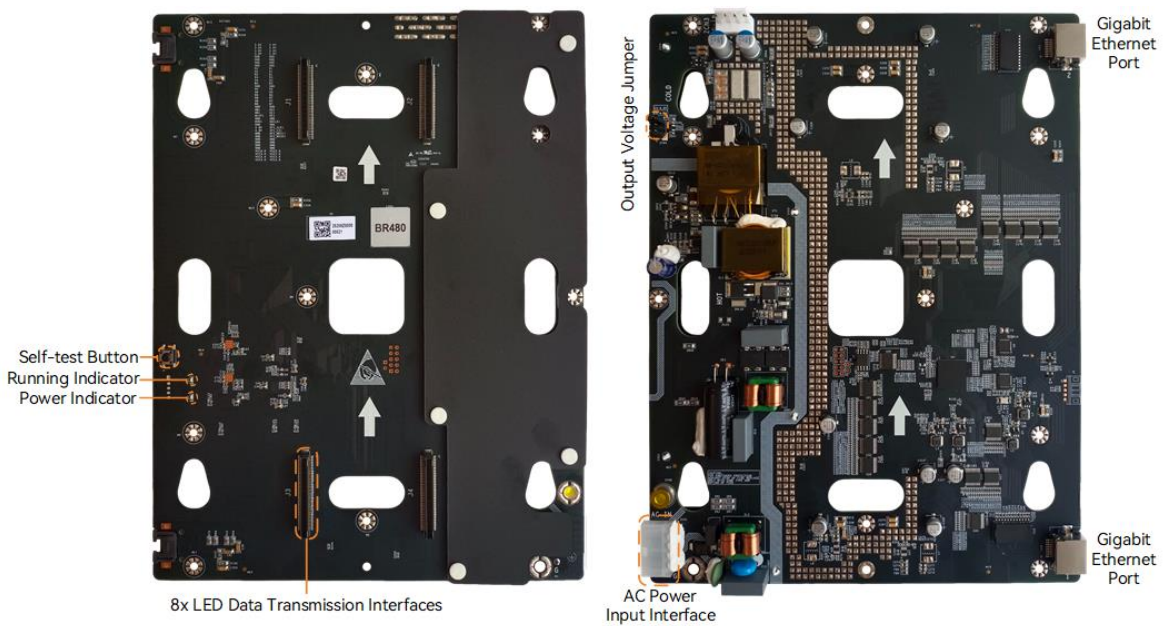

All product pictures shown in this document are for illustration purpose only. Actual product may vary.

## Indicator

Indicators	Color	Status	Description
Running indicator	Green	Flashing once every 1s	The receiving card is functioning normally. Ethernet cable connection is normal, and video source input is

Indicators	Color	Status	Description
			available.
		Flashing once every 3s	Ethernet cable connection is abnormal.
		Flashing 3 times every 0.5s	Ethernet cable connection is normal, but video source input is unavailable.
		Flashing once every 0.2s	The receiving card failed to load the program in the application area and is now using the backup program.
		Flashing 8 times every 0.5s	A redundancy switchover occurred on the Ethernet port and the loop backup has taken effect.
Power indicator	Red	Always on	The power input is normal.

## Dimensions

The board thickness is not greater than 2.0 mm, and the total thickness (board thickness + thickness of components on the top and bottom sides) is not greater than 22.0 mm.

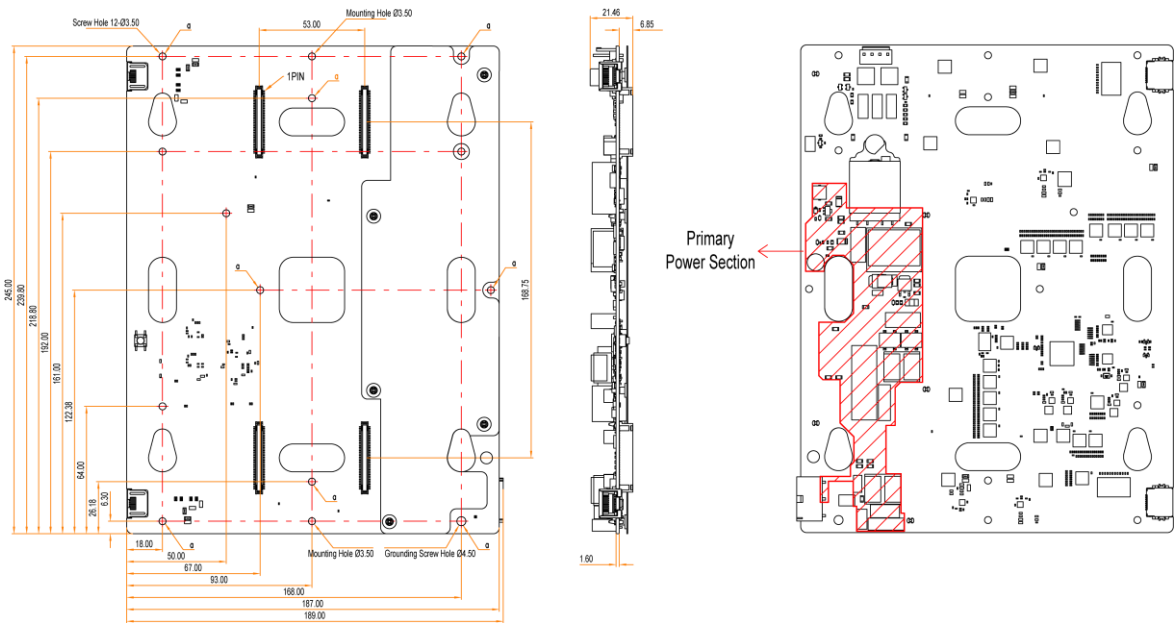

Tolerance: ±0.3 Unit: mm

**Note**

In accordance with the compatibility of three-in-one receiving cards, the spot marked "a" in the diagram is the recommended mounting hole locations. Other mounting hole locations can be adapted based on specific needs.

**Note**

- To make molds or trepan mounting holes, please contact NovaStar for a higher-precision structural drawing.
- The thermal conductive pad and silicone insulation pad are not included with the product. You will need to adhere them yourself according to the specified positions and sizes in the diagram. Attach the thermal conductive pad to the card, ensuring the thickness is appropriate for the available space in the cabinet and that it is compressed when in place. The silicone insulation pad should be adhered to the cabinet.
- The red shaded area in the diagram is the primary power section. Ensure a safety distance of at least 5 mm between this area and the metal conductor of the cabinet. If this distance is not met, add a silicone insulation pad for additional insulation. Design the silicone pad to extend more than 5 mm beyond the primary power section.
- For other areas, maintain a safety distance of at least 2 mm from the cabinet.
- The silicone pad should be 0.23 mm thick, with a voltage resistance of  $\geq AC/4KV$  and a thermal conductivity of  $\geq 1.6 W/m.k$ .

**Pins**

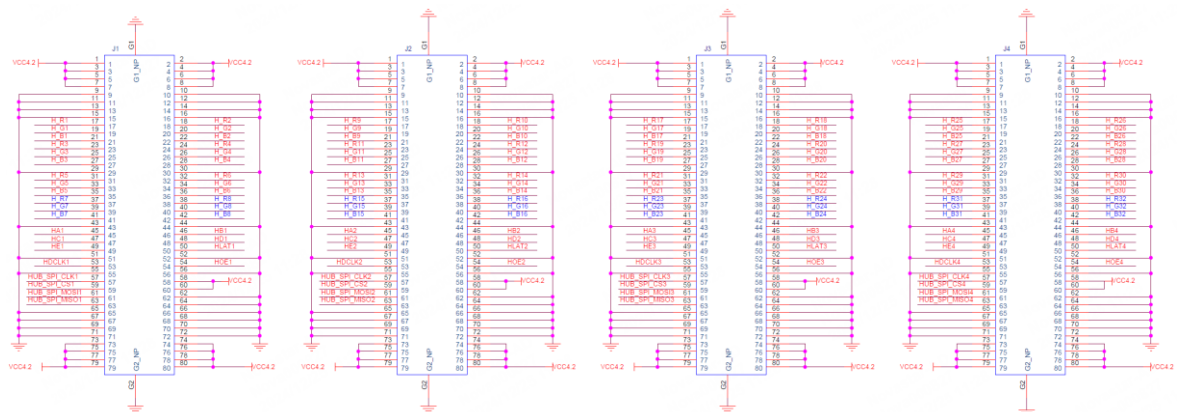

Pin Definitions (J1 as an example)					
/	VCC4.2	1	2	VCC4.2	/
/	VCC4.2	3	4	VCC4.2	/
/	VCC4.2	5	6	VCC4.2	/

Pin Definitions (J1 as an example)					
/	VCC4.2	7	8	VCC4.2	/
/	GND	9	10	GND	/
/	GND	11	12	GND	/
/	GND	13	14	GND	/
/	GND	15	16	GND	/
/	H_R1	17	18	H_R2	/
/	H_G1	19	20	H_G2	/
/	H_B1	21	22	H_B2	/
/	H_R3	23	24	H_R4	/
/	H_G3	25	26	H_G4	/
/	H_B3	27	28	H_B4	/
/	GND	29	30	GND	/
/	H_R5	31	32	H_R6	/
/	H_G5	33	34	H_G6	/
/	H_B5	35	36	H_B6	/
/	H_R7	37	38	H_R8	/
/	H_G7	39	40	H_G8	/
/	H_B7	41	42	H_B8	/
/	GND	43	44	GND	/
Line decoding signal	HA1	45	46	HB1	Line decoding signal
Line decoding signal	HC1	47	48	HD1	Line decoding signal
Line decoding signal	HE1	49	50	HLAT1	Latch signal
/	GND	51	52	GND	/
Shift clock	HDCLK1	53	54	HOE1	Display enable signal
/	GND	55	56	GND	/
Clock signal of serial pin	HUB_SPI_CLK1	57	58	VCC4.0	/
CS signal of serial pin	HUB_SPI_CS1	59	60	VCC4.0	/
Module flash data storage	HUB_SPI_MOSI1	61	62	GND	/

Pin Definitions (J1 as an example)					
input					
Module flash data storage output	HUB_SPI_MISO1	63	64	GND	/
/	GND	65	66	GND	/
/	GND	67	68	GND	/
/	GND	69	70	GND	/
/	GND	71	72	GND	/
/	VCC4.2	73	74	VCC4.2	/
/	VCC4.2	75	76	VCC4.2	/
/	VCC4.2	77	78	VCC4.2	/
/	VCC4.2	79	80	VCC4.2	/

## Electrical Specifications

### Input Specifications

Input Voltage	90 Vac to 264 Vac
Nominal Input	100 Vac to 240 Vac
Frequency Range	47 Hz to 63 Hz
Starting Voltage	> 70 Vac
Maximum Input Current	1.2 A
Inrush Current	Cold start: 100 A at 240 Vac, 50 A at 100 Vac
Power Factor	-
Current Harmonics	GB17625.1; EN61000-3-2,-3
Standby Power Consumption	≤ 4W
Input Fuse	T5AL/250 Vac

## Output Specifications

Output Current	20 A (Rated) 20 A (Maximum) Note: The peak current is tested with a pulse width of less than 100ms and at an ambient temperature of 30°C.
Output Voltage	3.8 V / 4.0 V / 4.2 V Default to 4.2 V with three adjustable settings in total. Users can use jumpers to short-circuit them to select the desired setting.
Output Voltage Accuracy	±2.0%
Line Regulation	±2.0%
Load Regulation	±2.0%
Output Ripple Noise	≤ 200mV Note: In an environment of 25°C, the bandwidth is set to 20 MHz. A 0.1 μF ceramic capacitor and a 10 μF electrolytic capacitor are connected in parallel at the output for testing.
Temperature Coefficient	Pending
Dynamic Load Performance	25% to 50% load and 50% to 75% load, < 10%
Efficiency	@240 Vac, 88%, CH1 20 A (rated) @100 Vac, 84%, CH1 20 A (rated)
Output Rise Time	30.0ms max Note: Rise time is defined as the time it takes for the output voltage to increase from 10% to 90%. This is tested with a 0.1 μF ceramic capacitor and a 10 μF electrolytic capacitor connected in parallel at the output.
Start-up Delay Time	Max 1s at 220 Vac
Output Hold Time	@ 240 Vac, 15ms @ 100 Vac, 10ms
Output Voltage Overshoot	10% max Note: All DC output currents should range from minimum to maximum values.
Capacitive Load	20000uF
Ratio Radiation Emission	Pending

Switching Frequency	Pending
Power Temperature Derating	-20°C to +70°C (Above 50°C, reduce load by 1.5% for every additional 1°C)
Power Input Voltage Derating	Between 90 Vac and 100 Vac, for every 1 V decrease, reduce load by 1.5%
MTBF	≥ 150,000 hours at 25°C ambient temperature, with full load and normal input

Temperature Derating Curve

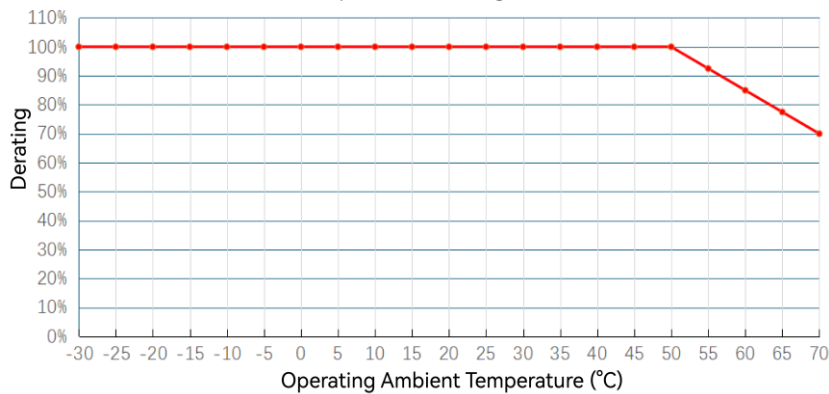

Input Voltage Derating Curve

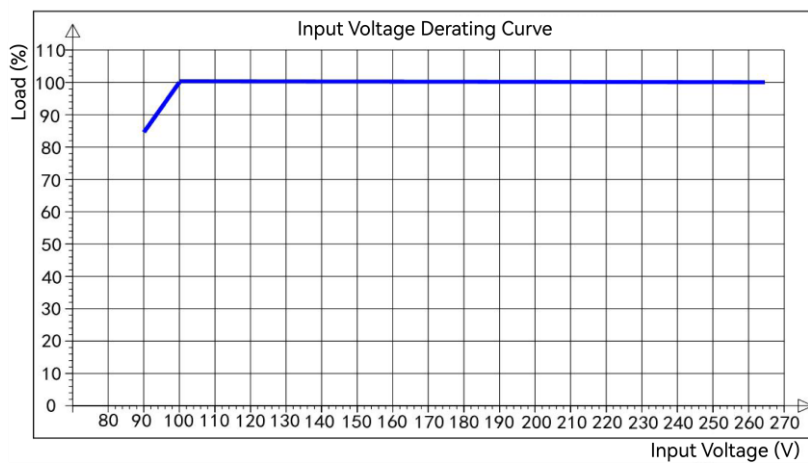

## Protection

Input Undervoltage Protection	Engages above 70 Vac, disengages below 65 Vac
Output Overvoltage Protection	< 6.5 V, self-recovery
Output Overcurrent Protection	More than 1.1 times
Output Overpower Protection	More than 1.1 times
Output Short-circuit Protection	Self-recovery

## Safety

Insulation Resistance	Input to output 500 Vdc, 100 MΩ min (at room temperature)
Insulation Withstand Voltage	Input to output (I/P-O/P): 3.0 kVac / 10 mA Input to case (I/P-CASE): 1.8 kVac / 10 mA Output to case (O/P-CASE): 500 Vdc / 10 mA Note: This refers to AC withstand voltage. The DC withstand voltage is 1.414 times the AC withstand voltage, while the leakage current remains the same.
Ground Resistance	< 0.1 Ω

### Note

If there are lightning protection components in the circuit, the following steps should be taken during the voltage withstand test after disconnecting the air gap tube:

- The input lines (L&N) need to be short-circuited together, and all the output lines need to be short-circuited together.
- Input to output: Input short-circuit line to output short-circuit line test.
- Input to FG: Input short-circuit line to FG.

## EMC

Conducted Emission	GB/T9254.1-2021/EN55032/FCC, Class A
Radiated Emission	GB/T9254.1-2021/EN55032/FCC, Class A
Power Fluctuation and Flicker	Pending
Radiated Susceptibility	EN55024; EN61000-4-2, 3, 4, 5, 6, 8, 11
Conducted Susceptibility	EN55024; EN61000-4-2, 3, 4, 5, 6, 8, 11
Surge Susceptibility	GB17626.5/IEC61000-4-5 Performance Criteria: B DM: ±2 kV, CM: ±4 kV
EFT Immunity	GB17626.4/IEC61000-4-4 Performance Criteria: B ± 3 kV
ESD Immunity	GB17626.2/IEC61000-4-2 Performance Criteria: B

	Contact $\pm 4$ kV, Air $\pm 8$ kV
Voltage Fluctuation and Flicker	Pending
Voltage Drop	GB17626.11/IEC61000-4-11 Performance Criteria: B/C

**Voltage Drop Requirements:**

Voltage Drop	Duration	Performance Criteria
0% Ut	10ms	B
70% Ut	500ms	C
40% Ut	200ms	C
0% Ut	5000ms	C

**Caution**

It is required to comply with the above-mentioned standards as a whole system.

If the product does not have the relevant certifications required by the countries or regions where it is to be sold, please contact NovaStar to confirm or address the problem. Otherwise, the customer shall be responsible for the legal risks caused or NovaStar has the right to claim compensation.

## Specifications

Maximum Resolution	For PWM driver ICs, the maximum load capacity per card is:	
	<ul style="list-style-type: none"> <li>• 512×384@60Hz (For 8bit video sources)</li> <li>• 512×256@60Hz (For 10bit and 12bit video sources)</li> </ul>	
Operating Environment	Temperature	-20°C to +70°C (Above 50°C, load capacity is reduced by 1.5% for every additional 1°C.)
	Humidity	10% RH to 90% RH, non-condensing
	Altitude	-60 m to +5000 m Note: For every 100 meters above 2000 meters in altitude, the maximum operating temperature decreases by 0.5°C.
Storage Environment	Temperature	-40°C to +85°C
	Humidity	5% RH to 95% RH, non-condensing
	Altitude	< 5000 m

Physical Specifications	Dimensions	245.0 mm × 189.0 mm × 21.5 mm
	Net weight	268.7 g Note: It is the weight of a single receiving card only.
Packing Information	Packaging	An antistatic bag is provided for each board. Each packing box contains 24 boards.
	Packing box	635.0 mm × 595.0 mm × 283.0 mm

## Copyright

### **Copyright © 2026 Xi'an NovaStar Tech Co., Ltd. All Rights Reserved.**

No part of this document may be copied, reproduced, extracted or transmitted in any form or by any means without the prior written consent of Xi'an NovaStar Tech Co., Ltd.

### **Trademark**

 is a trademark of Xi'an NovaStar Tech Co., Ltd.

### **Statement**

Thank you for choosing NovaStar's product. This document is intended to help you understand and use the product. For accuracy and reliability, NovaStar may make improvements and/or changes to this document at any time and without notice. If you experience any problems in use or have any suggestions, please contact us via the contact information given in this document. We will do our best to solve any issues, as well as evaluate and implement any suggestions.

| [Official website](http://www.novastar.tech)  
| [www.novastar.tech](http://www.novastar.tech)

| [Technical support](mailto:support@novastar.tech)  
| [support@novastar.tech](mailto:support@novastar.tech)