

BR840-1 Pro

LED Display Control Board



Specifications

Change History

Document Version	Release Date	Description
V1.0.3	2026-04-01	Updated the maximum load capacity.
V1.0.2	2025-11-05	Updated the output voltage information.
V1.0.1	2025-07-22	<ul style="list-style-type: none">• Updated the dimensions diagram.• Updated the appearance diagram.• Updated the pins section.• Updated the net weight information.
V1.0.0	2024-12-02	First release.

Introduction

The BR840-1 Pro is an LED display control board developed by NovaStar Tech Co., Ltd. (hereinafter referred to as NovaStar). It integrated a power module converts 90 Vac to 264 Vac into direct current, which directly powers the screen modules. Furthermore, the product offers functions such as undervoltage, overvoltage, overcurrent, overpower, and short-circuit protections, ensuring safety, high efficiency, and good reliability.

- For PWM driver ICs, the maximum load capacity per card when used with M3 controllers is:
 - 512×512@60Hz (For 8bit video sources)
 - 512×256@60Hz (For 10bit and 12bit video sources)
- For PWM driver ICs, the maximum load capacity per card when used with COEX controllers is:
 - 512×512@60Hz (For 8bit and 10bit video sources)
 - 512×256@60Hz (For 12bit video sources)

Features

- Power Module and Receiving Card in One Package

The product supports input voltage of 90 Vac to 264 Vac and converts it to direct current to directly power the modules. Furthermore, the product offers functions such as undervoltage, overvoltage, overcurrent, overpower, and short-circuit protections.

- Multi-layer Grayscale Calibration

Work with NovaStar's high-precision calibration system to generate unique calibration coefficients for low-grayscale image parts to ensure their uniformity while supporting the traditional brightness and chroma calibration.

- Image Booster (Effects depend on driver IC)

- Color Management: Support standard (Rec.709 / DCI-P3 / Rec.2020) and custom color gamuts, enabling more precise colors on the screen.
- Precise Grayscale: Individually correct the 65,536 levels of grayscale (16bit) of the driver IC to fix the display problems at low grayscale conditions, such as brightness spikes, brightness dips, color cast and mottling. This function can also better assist other display technologies, such as 22bit+ and individual gamma adjustment for RGB, allowing for a smoother and uniform image.
- 22bit+: Improve the LED screen grayscale by 64 times to avoid grayscale loss due to low brightness and allow for a smoother image with more details in dark areas.

- Pixel Level Brightness and Chroma Calibration

Work with NovaStar's calibration system to calibrate the brightness and chroma of each pixel, effectively eliminating differences and enabling high consistency for both brightness and chroma.

- Quick Adjustment of Dark or Bright Lines

The different brightness of seams caused by splicing of modules or cabinets can be corrected to improve the visual experience. The correction is easy and takes effect immediately.

- Multi-batch Adjustment

Adjust the brightness of cabinets or modules to minimize display discrepancies caused by variations in production batches.

- Low Latency

Low Latency is enabled by default. For PWM driver ICs, the latency of video source on the receiving card end can be reduced to 1 frame. To use low latency with DCLK continuous PWM driver ICs, a customized firmware is required.

- 3D

Work with the controller that supports 3D function to enable 3D output.

- Individual Gamma Adjustment for RGB

Working with NovaLCT and the controller that supports this function, the receiving card supports individual adjustment to red gamma, green gamma and blue gamma, which can

effectively control image non-uniformity at low grayscale conditions and white balance offset, allowing for a more realistic image.

- 90° Image Rotation

The display image can be rotated in multiples of 90° (0°/90°/180°/270°).

- Module Flash Management

For modules with flash memory, the information stored can be managed, allowing for the storage and readback of calibration coefficients and module IDs.

- Mapping 1.1

The cabinet displays the Ethernet port, receiving card, and controller numbers in different colors, clearly showing the physical locations and connection topology of receiving cards.

- Settings of a Stored Image in the Receiving Card

The image displayed during startup, or displayed when the Ethernet cable is disconnected or there is no video signal can be customized.

- Temperature and Voltage Monitoring

Real-time monitoring of the temperature and voltage of the receiving card, without the need for other external devices.

- Bit Error Detection

Real-time monitoring of the communication of the Ethernet port on the receiving card which helps users troubleshoot network communication problems.

- Firmware Program Readback

The receiving card firmware program can be read back and saved to the local computer.

- Configuration Parameter Readback

The receiving card configuration parameters can be read back and saved to the local computer.

- Loop Backup

The receiving card and controller form a loop via the primary and backup line connections. When a fault occurs at a location of the lines, the screen can still display the image normally.

- Dual Backup of Configuration Parameters

The receiving card configuration parameters are stored in the application area and factory area of the receiving card at the same time. Users usually use the configuration parameters in the application area. If necessary, users can restore the configuration parameters in the factory area to the application area.

- Dual Program Backup

Two copies of firmware program are stored in the receiving card at the factory to avoid the problem that the receiving card may get stuck abnormally during program update.

Appearance

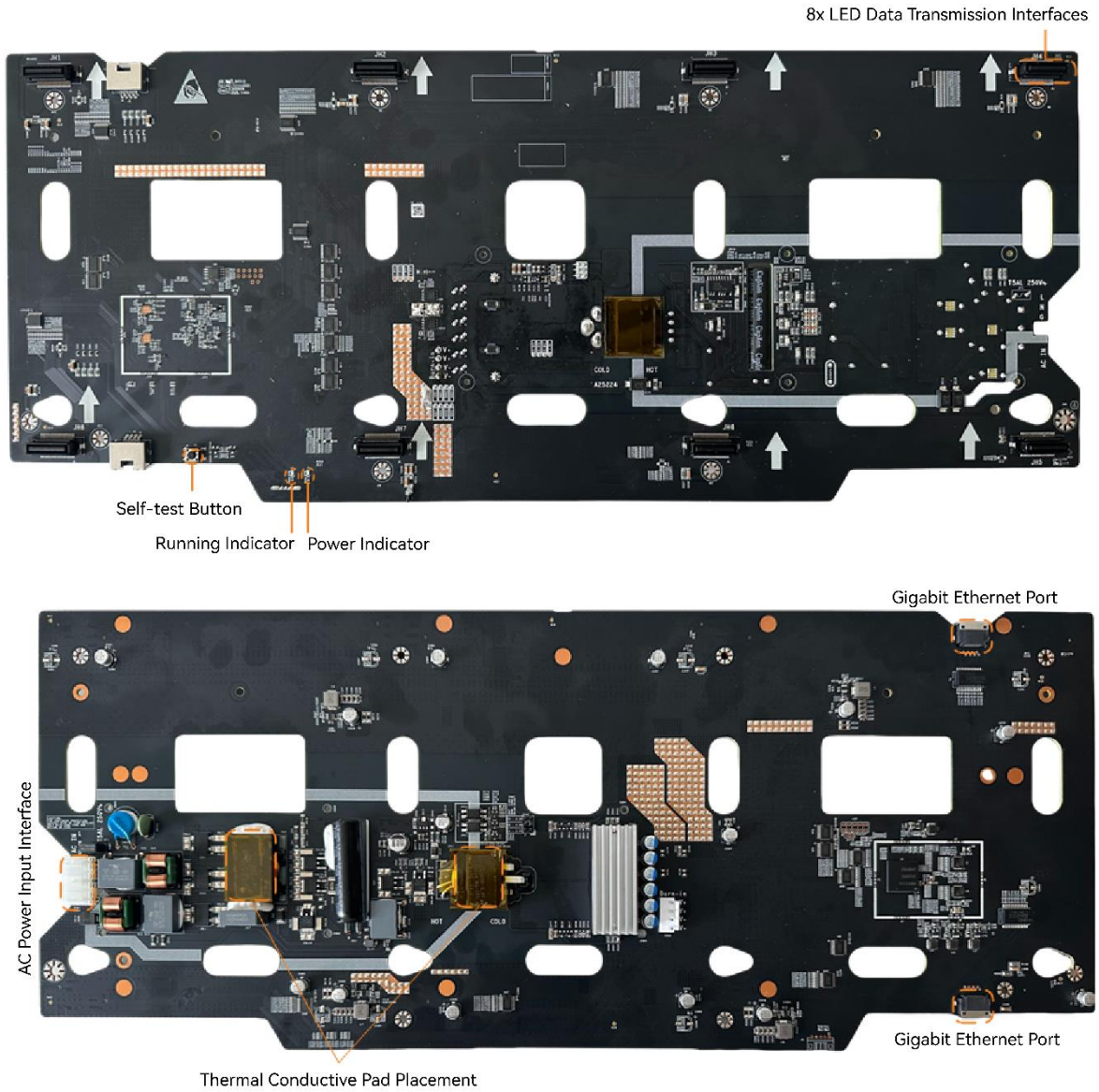

All product pictures shown in this document are for illustration purpose only. Actual product may vary.

Indicator

Indicators	Color	Status	Description
Running		Flashing once every	The receiving card is functioning normally. Ethernet

Indicators	Color	Status	Description
indicator	Green	1s	cable connection is normal, and video source input is available.
		Flashing once every 3s	Ethernet cable connection is abnormal.
		Flashing 3 times every 0.5s	Ethernet cable connection is normal, but video source input is unavailable.
		Flashing once every 0.2s	The receiving card failed to load the program in the application area and is now using the backup program.
		Flashing 8 times every 0.5s	A redundancy switchover occurred on the Ethernet port and the loop backup has taken effect.
Power indicator	Red	Always on	The power input is normal.

Dimensions

The board thickness is not greater than 2.0 mm, and the total thickness (board thickness + thickness of components on the top and bottom sides) is not greater than 23 mm.

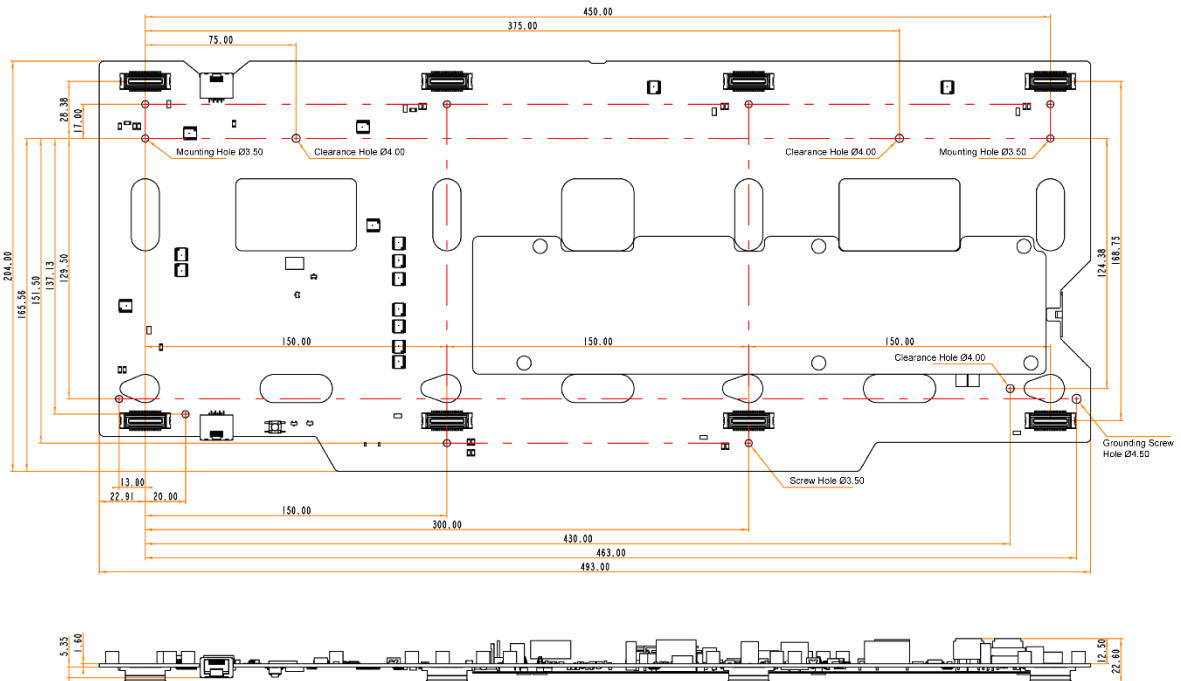

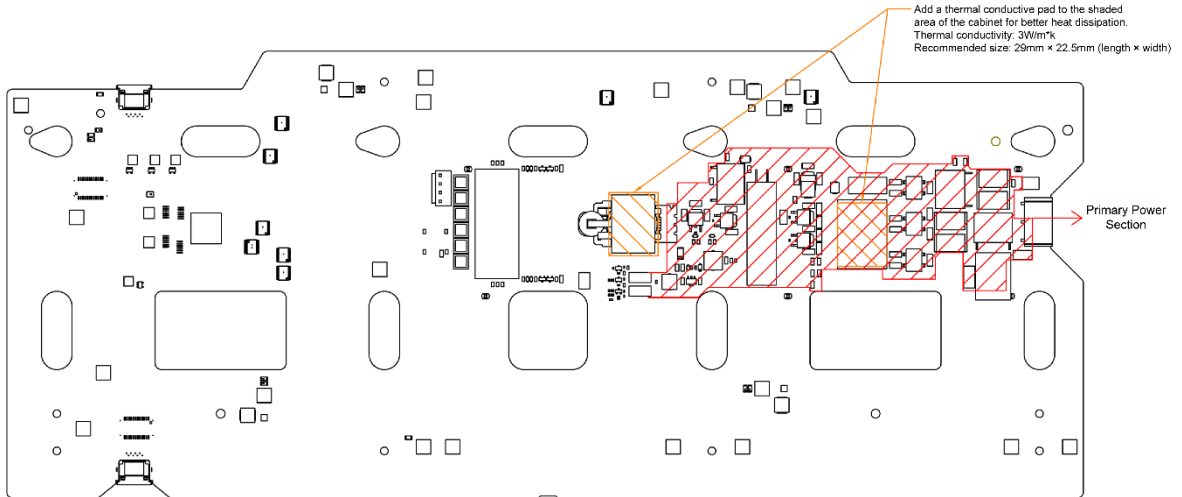

Tolerance: ±0.3 Unit: mm

Note

- To make molds or trepan mounting holes, please contact NovaStar for a higher-precision structural drawing.
- The thermal conductive pad and silicone insulation pad are not included with the product. You will need to adhere them yourself according to the specified positions and sizes in the diagram. Attach the thermal conductive pad to the card, ensuring the thickness is appropriate for the available space in the cabinet and that it is compressed when in place. The silicone insulation pad should be adhered to the cabinet.
- The red shaded area in the diagram is the primary power section. Ensure a safety distance of at least 5mm between this area and the metal conductor of the cabinet. If this distance is not met, add a silicone insulation pad for additional insulation. Design the silicone pad to extend more than 5mm beyond the primary power section.
- For other areas, maintain a safety distance of at least 2mm from the cabinet.
- The silicone pad should be 0.23mm thick, with a voltage resistance of ≥AC/4KV and a thermal conductivity of ≥1.6W/m.k.

Pins

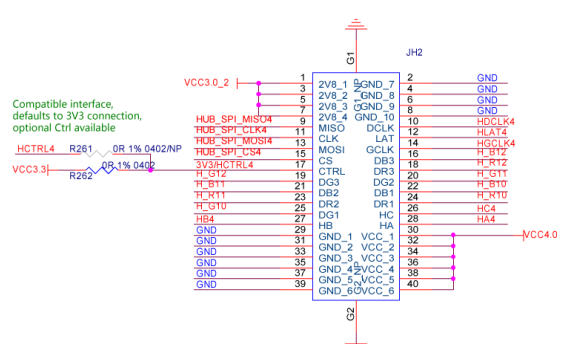
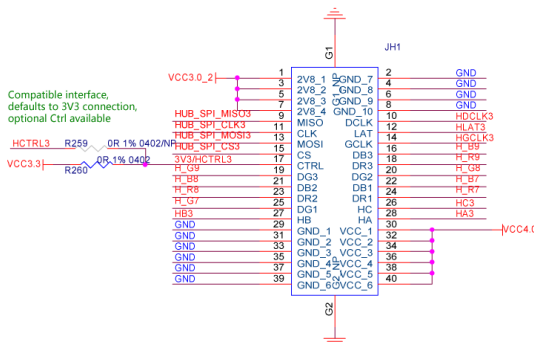

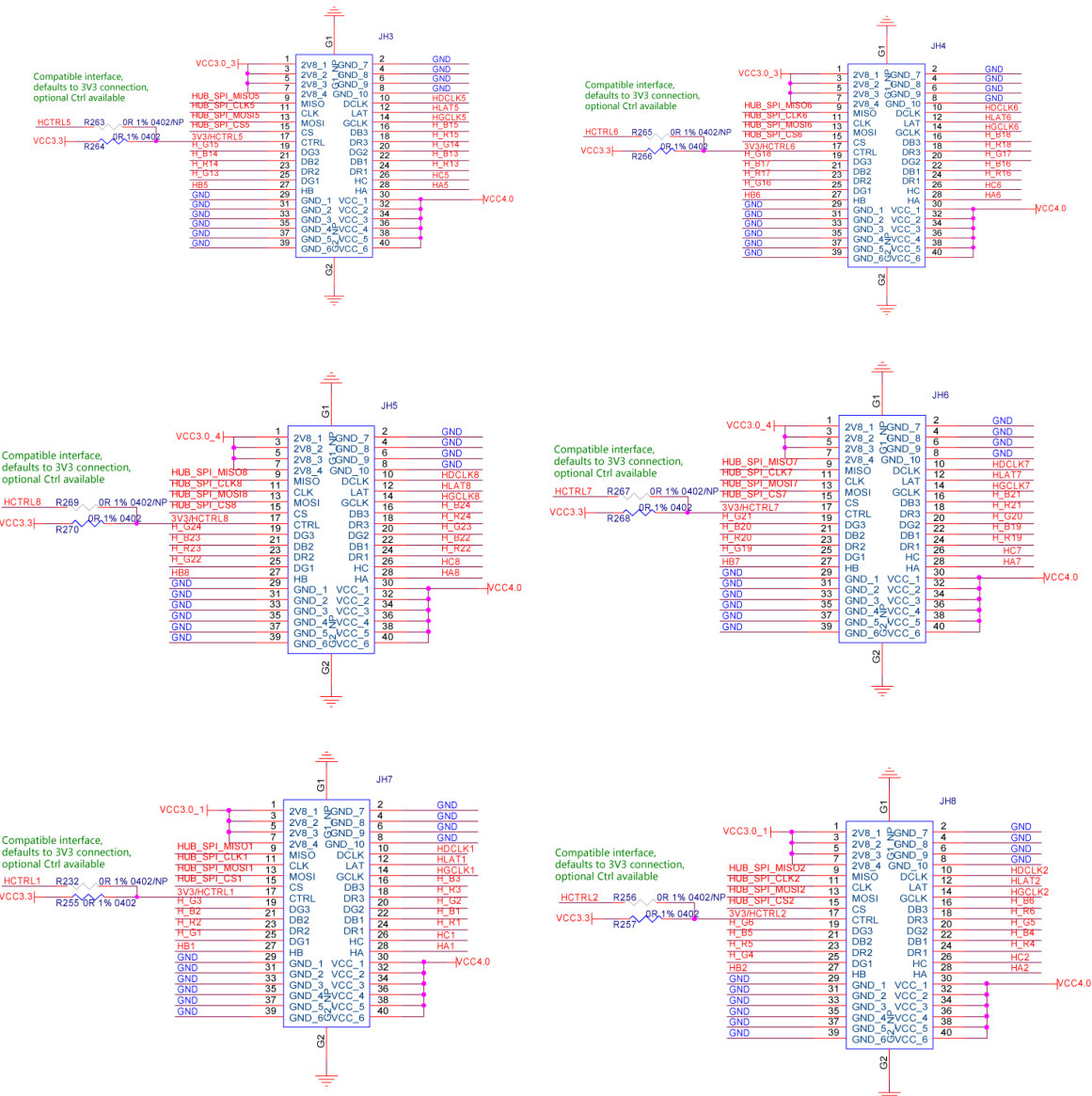

Pin Definitions (JH7 as an example)					
/	VCC3.0_1	1	2	GND	/
/	VCC3.0_1	3	4	GND	/
/	VCC3.0_1	5	6	GND	/
/	VCC3.0_1	7	8	GND	/
Module flash data storage output	HUB_SPI_MISO1	9	10	HDCLK1	Shift clock
Clock signal of serial pin	HUB_SPI_CLK1	11	12	HLAT1	Latch signal
Module flash data storage input	HUB_SPI_MOSI1	13	14	HGCLK1	Grayscale clock

Pin Definitions (JH7 as an example)					
CS signal of serial pin	HUB_SPI_CS1	15	16	H_B3	/
Afterglow Control Signal (optional)/3V3 voltage (default)	3V3/HCTRL1	17	18	H_R3	/
/	H_G3	19	20	H_G2	/
/	H_B2	21	22	H_B1	/
/	H_R2	23	24	H_R1	/
/	H_G1	25	26	HC1	Line decoding signal
Line decoding signal	HB1	27	28	HA1	Line decoding signal
/	GND	29	30	VCC4.0	/
/	GND	31	32	VCC4.0	/
/	GND	33	34	VCC4.0	/
/	GND	35	36	VCC4.0	/
/	GND	37	38	VCC4.0	/
/	GND	39	40	VCC4.0	/

Electrical Specifications

Input Specifications

Input Voltage	90 Vac to 264 Vac
Nominal Input	100 Vac to 240 Vac
Frequency Range	47Hz to 63Hz
Starting Voltage	> 70 Vac
Maximum Input Current	2.3A
Inrush Current	Cold start: 100 A at 240 Vac, 50 A at 100 Vac
Power Factor	@ 240 Vac \geq 0.90; @ 100 Vac \geq 0.97
Current Harmonics	GB17625.1; EN61000-3-2,-3

Standby Power Consumption	≤ 4W
Input Fuse	T5AL/250 Vac

Output Specifications

Output Current	32A (Rated) Note: The peak current is tested with a pulse width of less than 100ms and at an ambient temperature of 30°C.
Output Voltage	Adjustable voltage: 3.8 V/4.0 V/4.2 V Low voltage: 3.0 V Offers three adjustable settings, which can be changed by simply connecting a jumper cap.
Output Voltage Accuracy	±2.0%
Line Regulation	±2.0%
Load Regulation	±2.0%
Output Ripple Noise	≤ 200mV Note: In an environment of 25°C, the bandwidth is set to 20 MHz. A 0.1 μF ceramic capacitor and a 10 μF electrolytic capacitor are connected in parallel at the output for testing.
Temperature Coefficient	Pending
Dynamic Load Performance	0% to 50% load and 50% to 100% load, < 10%
Efficiency	@ 240 Vac, 88%, CH1 36 A @ 100 Vac, 84%, CH1 36 A
Output Rise Time	30.00ms max Note: Rise time is defined as the time it takes for the output voltage to increase from 10% to 90%. This is tested with a 0.1 μF ceramic capacitor and a 10 μF electrolytic capacitor connected in parallel at the output.
Start-up Delay Time	Max 1s at 220 Vac
Output Hold Time	@ 240 Vac, 15ms @ 100 Vac, 10ms

Output Voltage Overshoot	10% max Note: All DC output currents should range from minimum to maximum values.
Capacitive Load	32900uF
Ratio Radiation Emission	Pending
Switching Frequency	Pending
Power Temperature Derating	-20°C to +70°C (Above 50°C, reduce load by 1.5% for every additional 1°C)
Power Input Voltage Derating	Between 90 Vac and 100 Vac, for every 1 V decrease, reduce load by 1.5%
MTBF	≥ 100,000 hours at 25°C

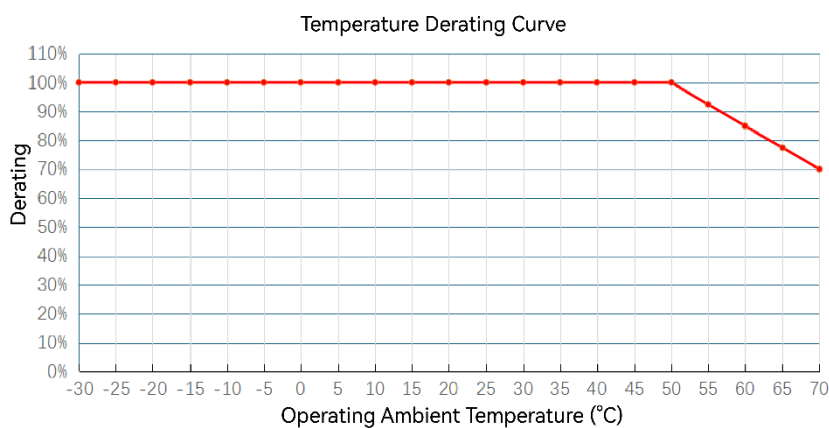
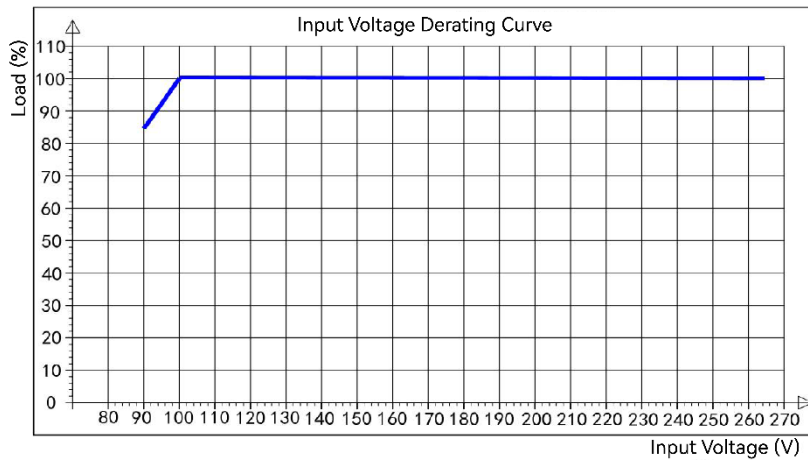

Protection

Input Undervoltage Protection	Engages above 70 Vac, disengages below 65 Vac
-------------------------------	---

Output Overvoltage Protection	< 6.5 V, self-recovery
Output Overcurrent Protection	Triggered at 1.3 to 1.6 times of rated current
Output Overpower Protection	Triggered at 1.3 to 1.6 times of rated current
Output Short-circuit Protection	Self-recovery

Safety

Insulation Resistance	Input to output 500 Vdc, 100 MΩ min (at room temperature)
Insulation Withstand Voltage	Input to output (I/P-O/P): 3.0 kVac / 10 mA Input to case (I/P-CASE): 1.8 kVac / 10 mA Note: This refers to AC withstand voltage. The DC withstand voltage is 1.414 times the AC withstand voltage, while the leakage current remains the same.
Ground Resistance	Ground resistance < 0.1 Ω

Note

If there are lightning protection components in the circuit, the following steps should be taken during the voltage withstand test after disconnecting the air gap tube:

- The input lines (L&N) need to be short-circuited together, and all the output lines need to be short-circuited together.
- Input to output: Input short-circuit line to output short-circuit line test.
- Input to FG: Input short-circuit line to FG.

EMC

Conducted Emission	GB/T9254.1-2021/EN55032/FCC, Class A
Radiated Emission	GB/T9254.1-2021/EN55032/FCC, Class A
Power Fluctuation and Flicker	Pending
Radiated Susceptibility	EN55024; EN61000-4-2, 3, 4, 5, 6, 8, 11
Conducted	EN55024; EN61000-4-2, 3, 4, 5, 6, 8, 11

Susceptibility	
Surge Susceptibility	GB17626.5/IEC61000-4-5 Performance Criteria: B DM: ± 2 kV, CM: ± 4 kV
EFT Immunity	GB17626.4/IEC61000-4-4 Performance Criteria: B ± 3 kV
ESD Immunity	GB17626.2/IEC61000-4-2 Performance Criteria: B Contact ± 4 kV, Air ± 8 kV
Voltage Fluctuation and Flicker	Pending
Voltage Drop	GB17626.11/IEC61000-4-11 Performance Criteria: B/C

Voltage Drop Requirements:

Voltage Drop	Duration	Performance Criteria
0% Ut	10ms	B
70% Ut	500ms	C
40% Ut	200ms	C
0% Ut	5000ms	C

Caution

It is required to comply with the above-mentioned standards as a whole system.

If the product does not have the relevant certifications required by the countries or regions where it is to be sold, please contact NovaStar to confirm or address the problem. Otherwise, the customer shall be responsible for the legal risks caused or NovaStar has the right to claim compensation.

Specifications

Maximum Resolution	<ul style="list-style-type: none"> • For PWM driver ICs, the maximum load capacity per card when used with M3 controllers is: <ul style="list-style-type: none"> – 512×512@60Hz (For 8bit video sources)
--------------------	---

		<ul style="list-style-type: none"> - 512×256@60Hz (For 10bit and 12bit video sources) • For PWM driver ICs, the maximum load capacity per card when used with COEX controllers is: <ul style="list-style-type: none"> - 512×512@60Hz (For 8bit and 10bit video sources) - 512×256@60Hz (For 12bit video sources)
Operating Environment	Temperature	-20°C to +70°C (Above 50°C, reduce load by 1.5% for every additional 1°C)
	Humidity	10% RH to 90% RH, non-condensing
	Altitude	-60m to +5000m Note: For every 100 meters above 2000 meters in altitude, the maximum operating temperature decreases by 0.5°C.
Storage Environment	Temperature	-40°C to +85°C
	Humidity	5% RH to 95% RH, non-condensing
	Altitude	< 5000 m
Physical Specifications	Dimensions	493.0 mm × 204.0 mm × 22.6 mm
	Net weight	472.9 g Note: It is the weight of a single receiving card only.
Packing Information	Packaging	An antistatic bag is provided for each board. Each packing box contains 14 boards.
	Packing box	635.0 mm × 595.0 mm × 283.0 mm

Copyright

Copyright © 2026 Xi'an NovaStar Tech Co., Ltd. All Rights Reserved.

No part of this document may be copied, reproduced, extracted or transmitted in any form or by any means without the prior written consent of Xi'an NovaStar Tech Co., Ltd.

Trademark

 is a trademark of Xi'an NovaStar Tech Co., Ltd.

Statement

Thank you for choosing NovaStar's product. This document is intended to help you understand and use the product. For accuracy and reliability, NovaStar may make improvements and/or changes to this document at any time and without notice. If you experience any problems in use or have any suggestions, please contact us via the contact information given in this document. We will do our best to solve any issues, as well as evaluate and implement any suggestions.

| [Official website](http://www.novastar.tech)
| www.novastar.tech

| [Technical support](mailto:support@novastar.tech)
| support@novastar.tech